

PEINER

Schnellmontagekran SMK 201

Fast self erecting tower crane

Grue à montage rapide

Max. Tragfähigkeit	2,0 t
Lifting capacity	
Force de levage	
Max. Ausladung	22 m
Radius	
Portée	
Max. Nutzlastmoment	226 kNm
Load moment	
Couple de charge utile	

“City-Kran”

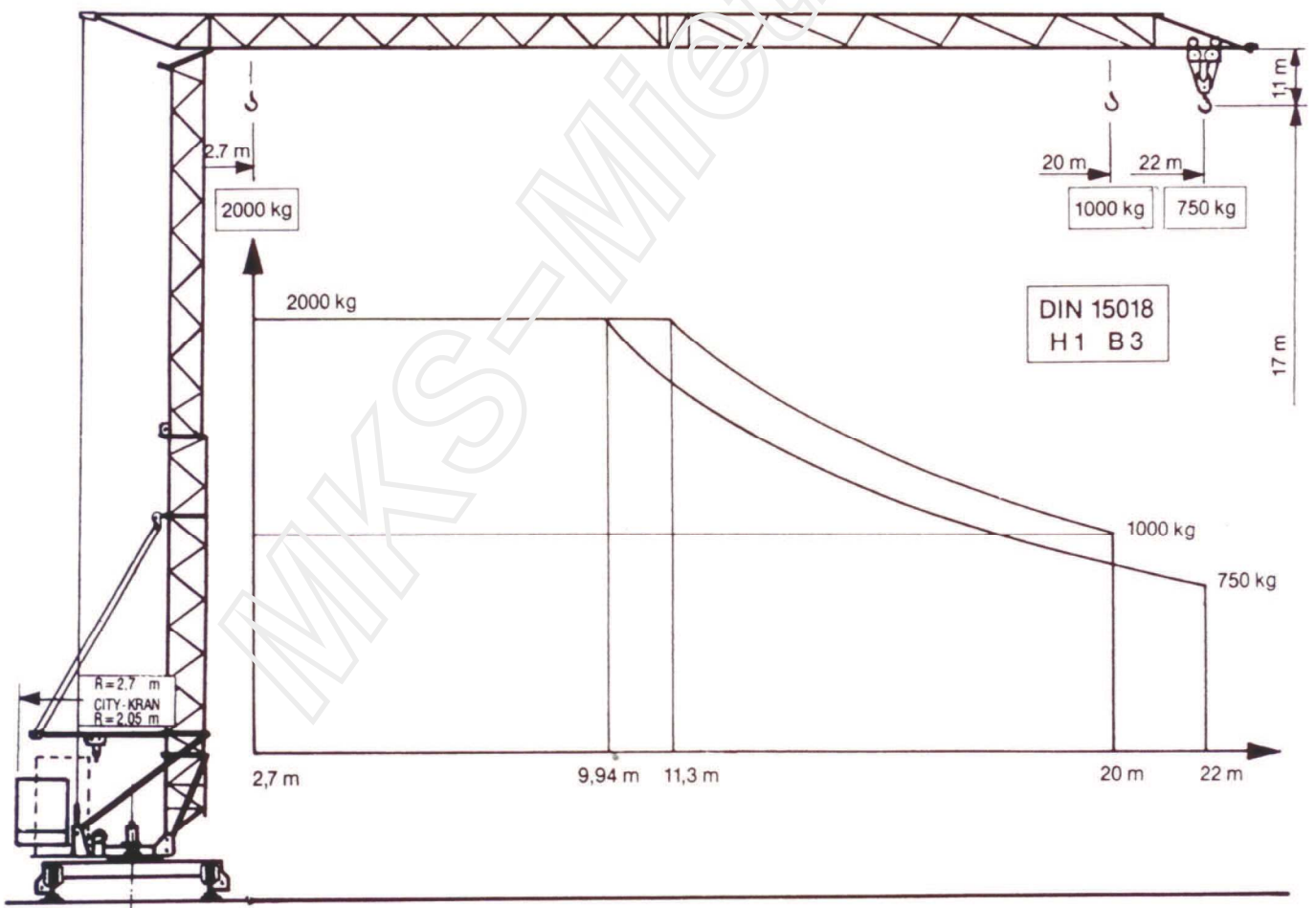

ZUTK Nr. 0622 + CE

Peiner Schnellmontagekran

Fast self erecting tower crane

Grue à montage rapide

SMK 201

Form 20 (BGL)

Geschwindigkeiten / speeds / Vitesses

Type				Motor- Leistung Power Puissance KW
PU 8/2			m/min. 40 kg 1000	7,5
			20 2000	
			5 m/min.	
KL 1/2		v = 30 m/min.		0,9
KL 1/3		v = 30 m/min. (Steilstellung 20° x 750 kg)		(1,8)
DIEO / 20		n = 0 → 0,9 min ⁻¹ SRA-System		1
380V / 50 Hz / 3 Ph		Anschlußwert / connection power / Puissance installée		10,5

Gewichte + Maße / weights and sizes / Poids et mesures

Konstruktionsgewicht Construction weight Poids de construction	kg	Standard-	City-Ausf.			
		ø500				
Gegengewicht Counterweight Contre-poids	kg	8300	10150	Kabeltrommel (Fahrweg) Cable winder (length of track) Enrouleur (longueur de voie)	m	40
		CH + 24% Zentralballast	+ 210% Zentralballast			
max. Eckdruck max. wheel load Pression max. par galot	kN	95		Kabelquerschnitt Cable cross section Section du câble	mm ²	4 x 6
Spurweite / Radstand track gauge / wheel gauge Ecartement de voie / Empatemen.	m	3,6 / 3,6		Steuerkabel Control cable Câble de commande	m	15
Drehradius Radius of rotation Rayon de rotation	m	2,7	2,05	Schienenprofil Rail profile Profil de rail		S 33/S49

Straßentransport

Road transport

Transport en route

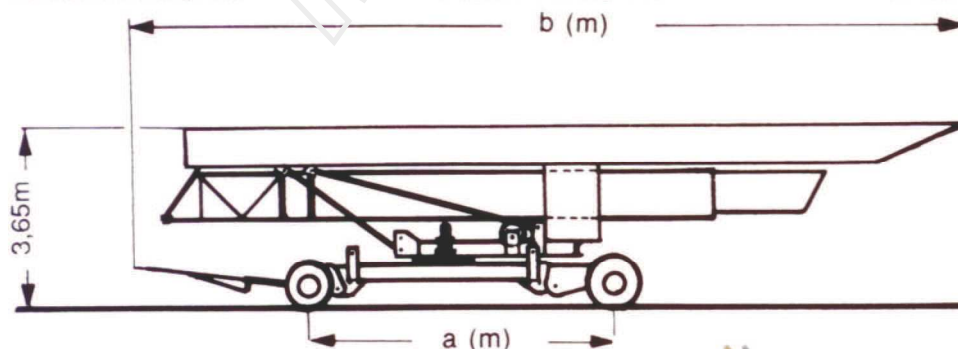

	a	b
KSL 14/1	5,78	14,60
KSL 20/1	6,03	14,40